

HEATLOCK®

YOUR GLOBAL HOT-RUNNER SOLUTION



HEATLOCK®

Global Hot Runner Solution Provider

Our passion is hot runner solutions and we pride ourselves on simplicity whilst maintaining maximum performance, achieving modular perfection.

Our Operation is set up according to international business standards with strict quality and management system as key ingredients. We have more than 30 years' experience with Hot Runner Solutions.

We supply standardised products or special hot runner solutions, hot half's all up to your specific requirements. All simulated in depth, if needed, by our global partners. Our network has top of the line tech know-how.

Ceramic insulated, CE technology

HEATLOCK Hot Runners are known for their ceramic insulation, which insulates all the contact- and location-points from the mould. With our patented CE fix technology have we made ceramics even easier to use with increased sustainability

Service fanatics

Heatlock is a service company fanatic about customer care, we deliver hot runner solutions, your lean partner.

Global partners

Throughout our global network of partners, HEATLOCK guarantees high quality service no matter where your mould is produced or in production. You make your mould in China, Germany, Portugal, UK.....our Global Call service takes care of you.

Tech centre and spare part stock in;

China * Germany * US

GLOBAL ASSISTANCE, HELP ANYWHERE=GLOBAL CALL BY HEATLOCK

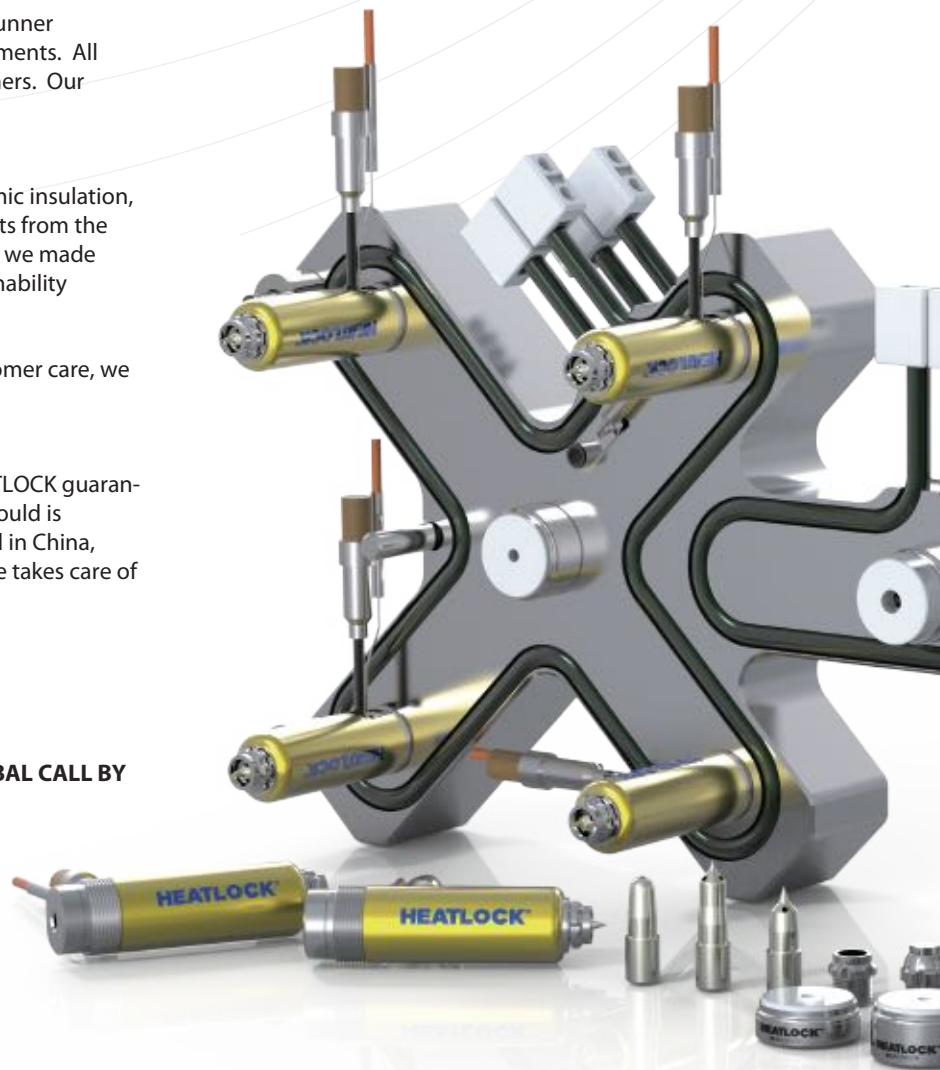

ALL-IN-ONE Technology

Hot Runners re-engineered to make it simple and easy to use with maximum performance and modularity. Commodity applications use the standard configurations for engineering resins simply up-grade with our high performance modules. Simply drop the Hot Runner system in your mould and adjust gate position to the optimum position using our virtual gate position technology, V-GATE.

All wire exits are to pre-determined once gate position is fixed. Grind back spacers to adjust for calculated heat expansion; close the clamp plate and you are ready to go.

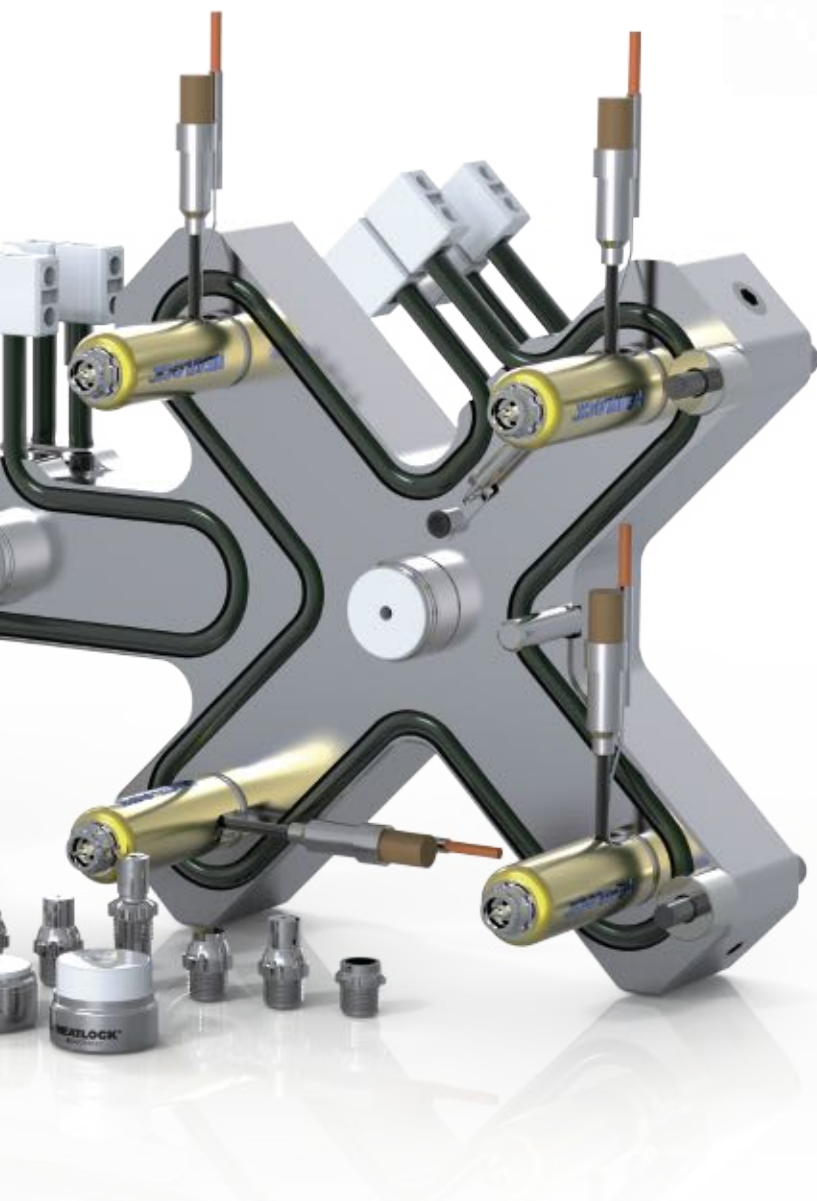
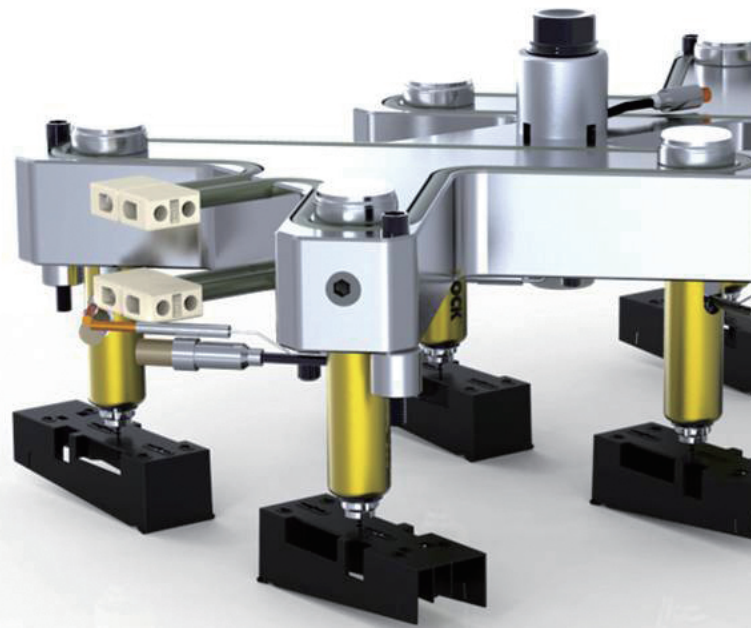

Ceramic Clamp Technology CE-FIX

Lateset development with our well proven ceramic insulation technology! We were the first Hot Runner provider to introduce Hot Runners with Ceramics in 1982. Ceramic insulation is superior compared with other materials. With the ceramic insulation HEAT LOCK inside your Hot Runner System. This result to less temperature drop on contact surfaces and still with excessive support surfaces to ensure mould stability at the same time energy saving. With our latest patented CE-FLX technology we have made ceramics even easier to use with increased sustainability, easy to install and adjust.

→ A3 Technology

ALL-IN-ONE technology



With it's unique new AO-LOCK system we secure the nozzles with the manifold to make the Hot Runner system leak free. All wire exits is to pre-determined position to ensure your designed wire slots match the Hot Runner system.

Select nozzle size, length and front style which suits the need of your parts gate requirement in our nozzle guide section.

We have 13 front styles to choose from, all available in one hole tip or three hole tip option.

(you can have one hole tips or three holes tips of our standard needle tip.) If you mould glass filled resins and needs a wear resistant tip for maximised life choose our TZM tip which is available in a one hole style. All tips are designed to give minimum stress to material while maintaining a(keeping a good) /stable/controlled gate temperature.

Simply drop the Hot Runner system in your mould and adjust gate position to your maximised position using our virtual gate position technology, V-GATE, can it get easier?

Front styles:

NSS/PSS: Nut style no visible gate mark on your part

NPS/PPS: Front style give you a ring gate mark on the part

NPX/PPX: Front extended style give you a ring gate mark on the part used on contoured parts or when you gate on a runner

NSX/PSX/VSX: Front extended style, Excellent for glass filled resins and high temperature moulding

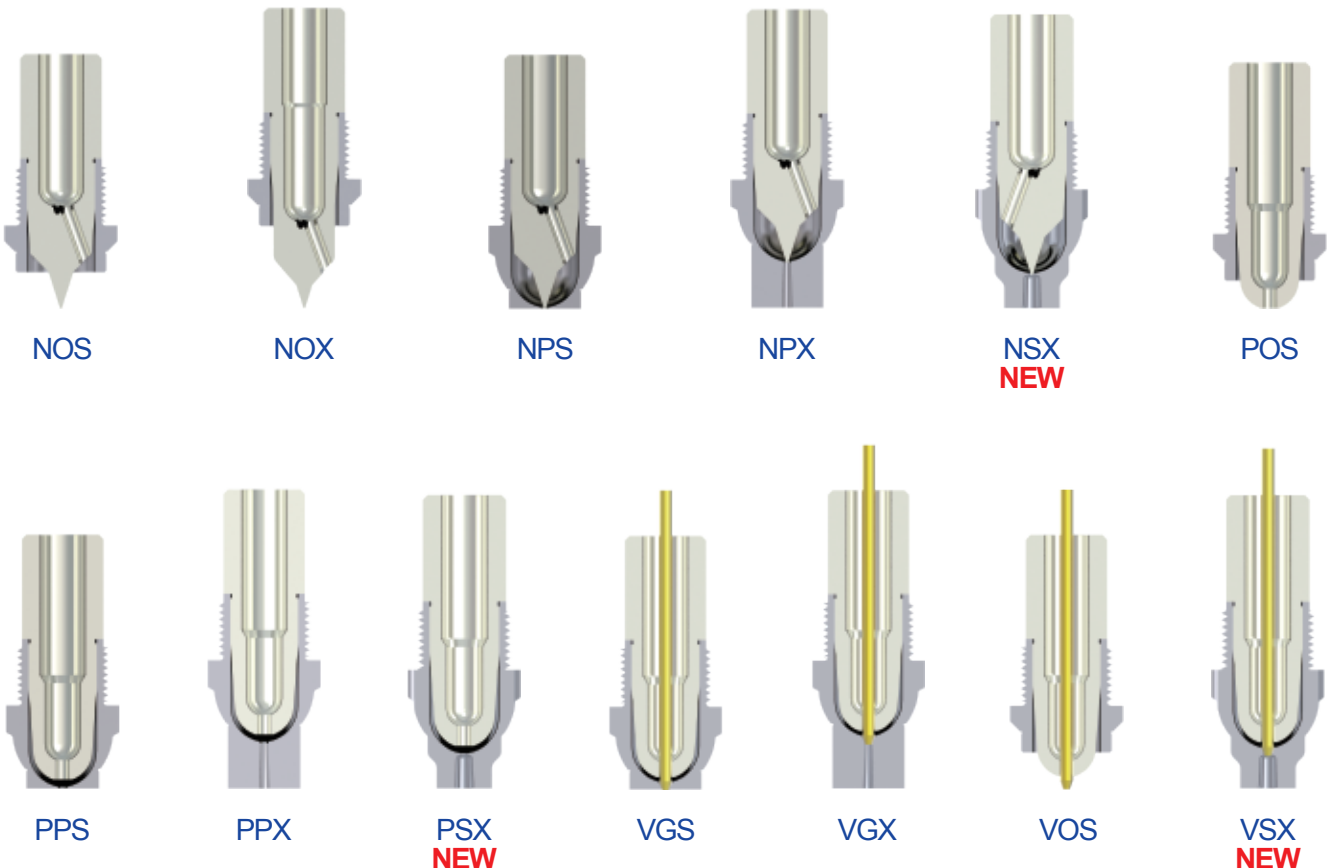

→ A3 Nozzle Selection Guide

(mm)

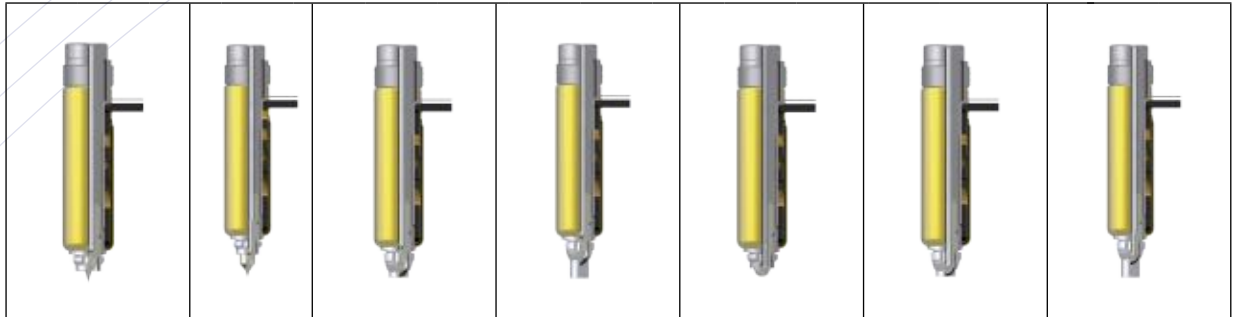

Type	NOS			NOX		NPS			NPX/NSX			POS			PPS			PPX/PSX		
Feed Φ	4	5	7	5	7	4	5	7	4	5	7	4	5	7	4	5	7	4	5	7
Gate Φ	0.6~1.5	0.6~2	0.8~3	0.6~2	0.8~3	0.6~1.5	0.6~2	0.8~3	0.6~1.5	0.6~2	0.8~3	0.6~1.5	0.6~2	0.8~3	0.6~1.5	0.6~2	0.8~3	0.6~1.5	0.6~2	0.8~3

Max. Recommended shot weight

Low	80	200	400	200	400	80	200	400	80	200	400	100	300	600	100	300	600	100	300	600
Medium	60	100	260	100	260	60	100	260	60	100	260	60	125	310	60	125	310	60	125	310
High	5	20	50	20	50	5	20	50	5	20	50	7	25	60	7	25	60	7	25	60

Suitability

PP	***	***	***	***	***	***	***	***	***	***	***	***	***	***	***	***	***	***	***	***
PS/PE	***	***	***	***	***	***	***	***	***	***	***	***	***	***	***	***	***	***	***	***
ABS/SAN	***	***	***	***	***	***	***	***	***	***	***	***	***	***	***	***	***	***	***	***
POM	***	***	***	***	***	***	***	***	***	***	***	***	***	***	***	***	***	***	***	***
LCP	*	*	*	*	*	*	*	*	*	*	*	*	*	*	*	*	*	*	*	*
PBT	*	*	*	*	*	*	*	*	*	*	*	*	*	*	*	*	*	*	*	*
PET	*	*	*	*	*	*	*	*	*	*	*	*	*	*	*	*	*	*	*	*
PA6/PA66	***	***	***	***	***	***	***	***	***	***	***	***	***	***	***	***	***	***	***	***
PC	***	***	***	***	***	***	***	***	***	***	***	***	***	***	***	***	***	***	***	***
PMMA	***	***	***	***	***	***	***	***	***	***	***	***	***	***	***	***	***	***	***	***
PPO	*	*	*	*	*	*	*	*	*	*	*	*	*	*	*	*	*	*	*	*
PES/PEK	*	*	*	*	*	*	*	*	*	*	*	*	*	*	*	*	*	*	*	*
PPS/PEI	*	*	*	*	*	*	*	*	*	*	*	*	*	*	*	*	*	*	*	*

Viscosity:

Low	Medium	High
-----	--------	------

*** Good ** Ok * Contact HEATLOCK -- Not recommended

All value above & approximate. For details regarding your product welcome to contact Heatlock.

→ A3 Gate Diameter

Gate Ø

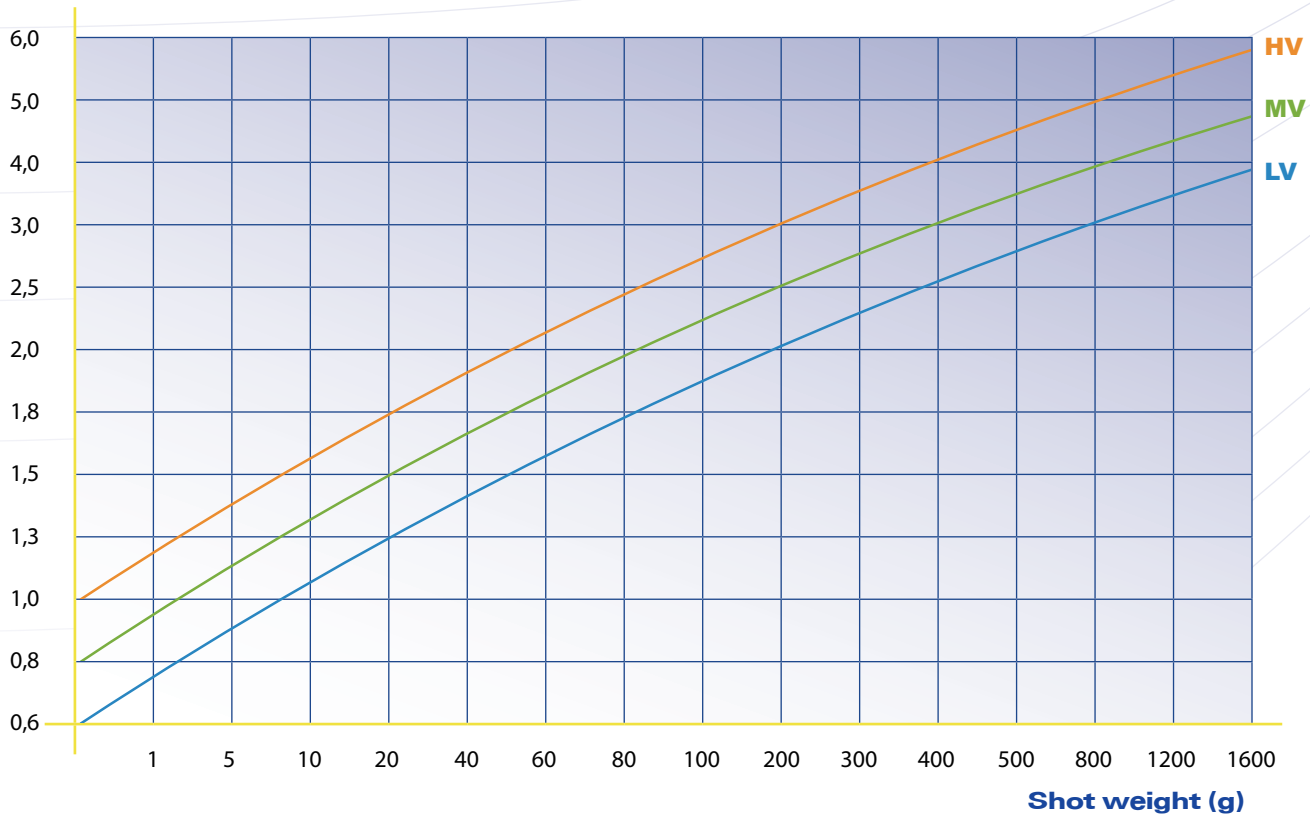

NOTE:

1. For "TP" type reduce gate Ø -30%
2. For filled materials increase gate Ø +20%

1. **LV** Low viscosity materials PS, PE, PP
2. **MV** Medium viscosity materials ABS, SAN, PA, POM
3. **HV** High viscosity materials PC, PMMA, PC/ABS, PUR

Above diagram is a guideline built on experience from thousands of applications. However is the result depending on numerous conditions in your mould; balance between shot weight, injection speed, injection pressure, mould temperature, temperature control around the gate area, temperature control opposite the gate.

A smaller gate freeze faster compared with a larger gate, a faster cycle time allow smaller gate, long cycle time requires bigger gate.

If cycle time is short and injection speed fast it may be necessary to design gate cooling to avoid gate to overheat.

When you gate on a runner is it recommended to make the gate slightly larger to reduce pressure drop and decrease shear rates. Runner shall be adjusted in size to suit Hot Runner moulding to get shortest cycle time.

Above diagram is a guideline only, final decision is to be decided by the moulder or simulation considering all factors of the process.

→ A3 NOS+NPS+NPX+NSX Series



NOS

- Topless direct gate small residue on the part
- One hole options for shear sensitive materials
- TZM one exit tips for reinforced materials

NPX

- Direct gate small residue on the part, reduced stringing
- One exit options for shear sensitive materials, TZM one exit tips for reinforced materials
- Gating on contour or with a sprue gate
- Exchangeable gate, gate separated from mould plate

NPS

- Direct gate small residue on the part, reduced stringing
- One exit options for shear sensitive materials, TZM one exit tips for reinforced materials
- Exchangeable gate, gate separated from mould plate

NSX

- Perfect hot to cold solution
- Direct gate on the part, reduced stringing
- One exit options for shear sensitive materials, TZM tips for reinforced materials
- Exchangeable front, gate separated from mould plate
- Excellent for glass filled resins and high temperature moulding



NOS



NPS



NPX



NSX
NEW

Size	Size 04	Size 05	Size 07
LA	64~114	64~134	74~174
Feed ϕ	4	5	7
Gate ϕ	0.6~1.5	0.6~2	0.8~3

Shot Weight(g)			
Low	80	200	400
Medium	60	100	260
High	5	20	50

→ A3 NOS+NPS+NPX+NSX Guide

Order example:

→ **A3 - NOS - 094 - 05 - 1 - 3**

Nozzle series Nut/Front type LA Feed dia. Tip mat. Exits in tip

Tip codes:

material: 1=copper alloy,3=HBM-CDC,4=TZM-SHN
Exits: 1=one exit,3=three exit

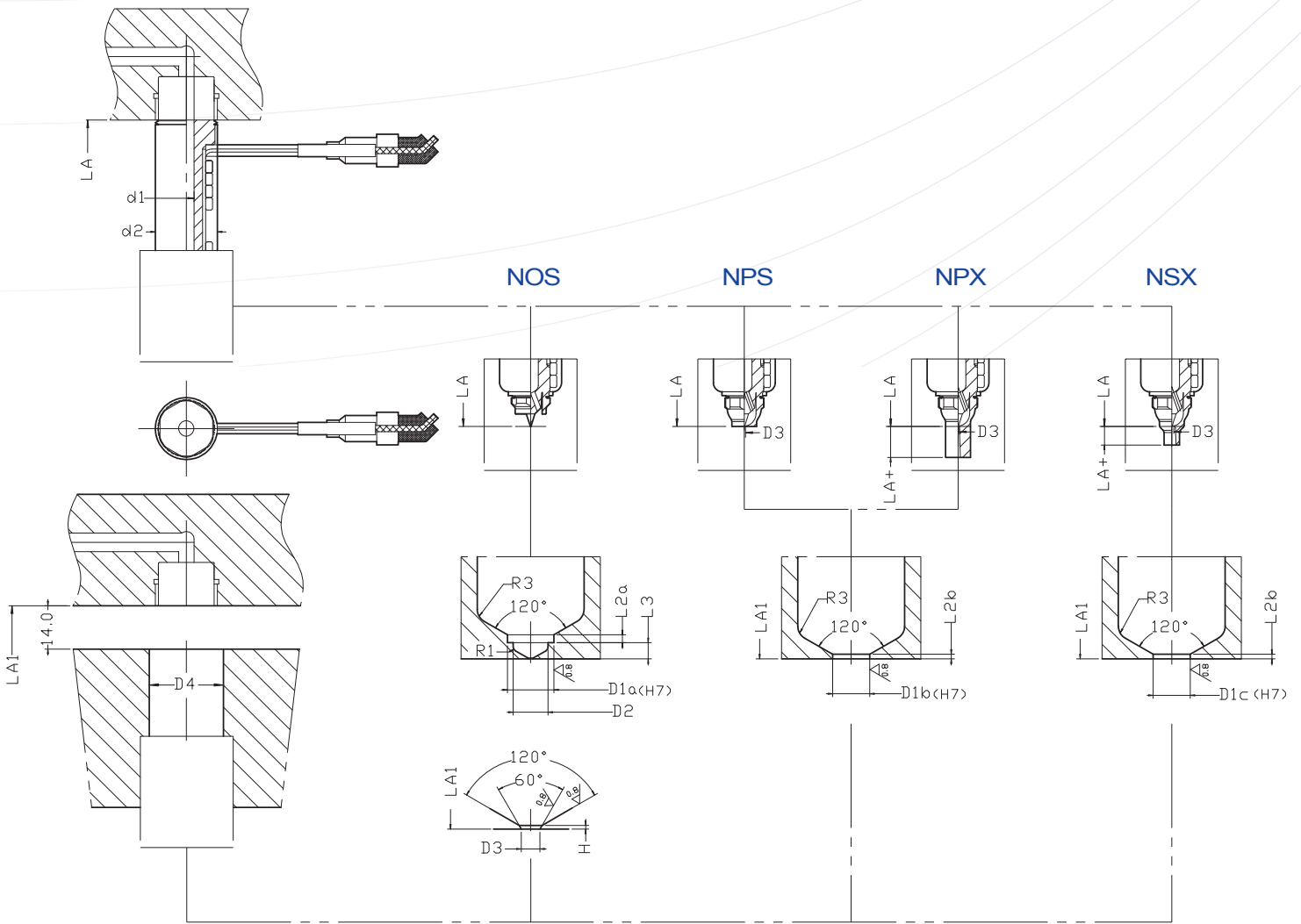

→ A3 NOS+NPS+NPX+NSX Dimension

(mm)

		A3+NOS NPS NPX NSX															
Nozzle	Size	04				05					07						
	LA	64	74	94	114	64	74	94	114	134	74	94	114	134	154	174	
	LA+	6				10(PX),6(SX)					15(PX),7(SX)						
	d1	4				5					7						
	d2	13				20					23						
Mould	LA1	64.15	74.17	94.21	114.25	64.15	74.17	94.21	114.25	134.29	74.17	94.21	114.25	134.29	154.33	174.37	
	L2a	1.1				2					2.5						
	L2b	1				1					1.5						
	L3	1.7				3.5					3.5						
	D1a	6				10					12						
	D1b	6				8					10						
	D1c	5				5					7						
	D2	4.5				7.5					9						
	D3	1.5≥0.6				2≥0.6					3≥0.8						
	D4	15				23					27						
	H	0.2				0.2					0.2						

→ A3 NOS+NPS+NPX+NSX Spare Parts

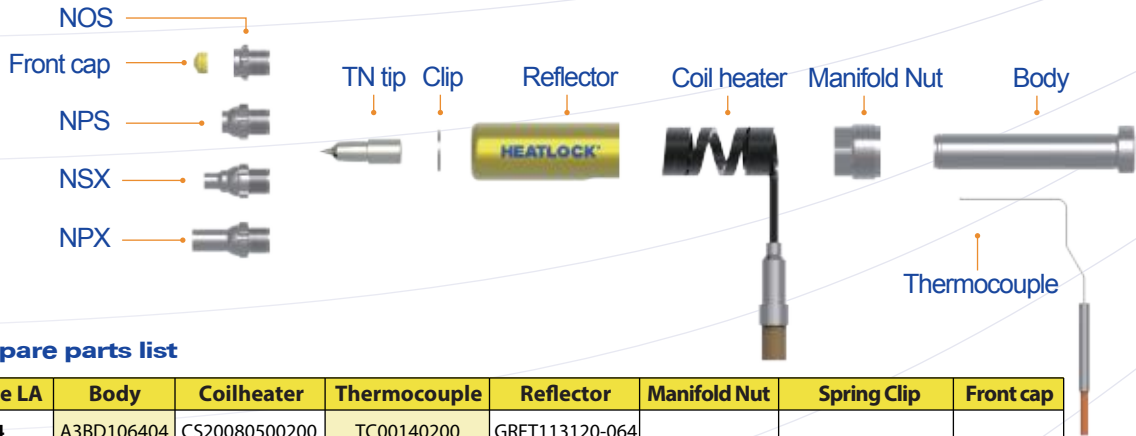

Nozzle body spare parts list

Size	Nozzle LA	Body	Coilheater	Thermocouple	Reflector	Manifold Nut	Spring Clip	Front cap
04	64	A3BD106404	CS20080500200	TC00140200	GRFT113120-064	A3KG1413	F-S-SPRINGCLIP-8408	A3FC044724 (optional)
	74	A3BD107404	CS20080600250	TC00140210	GRFT113120-074			
	94	A3BD109404	CS20080800300	TC00140220	GRFT113120-094			
	114	A3BD111404	CS20081000350	TC00140220	GRFT113120-114			
05	64	A3BD106405	CS14120430200	TC00140200	GRFT120120-064	A3KG2016	F-S-SPRINGCLIP-1210	A3FC057939 A3FC057949 (optional)
	74	A3BD107405	CS14120530225	TC00140210	GRFT120120-074			
	94	A3BD109405	CS14120730250	TC00140220	GRFT120120-094			
	114	A3BD111405	CS14120930350	TC00140220	GRFT120120-114			
	134	A3BD113405	CS14121130350	TC00140250	GRFT120120-134			
07	74	A3BD207407	CS14150510300	TC00140200	GRFT224200-074	A3KG2416	F-S-SPRINGCLIP-1410	A3FC079443 (optional)
	94	A3BD209407	CS14150710350	TC00140210	GRFT224200-094			
	114	A3BD211407	CS14150910450	TC00140220	GRFT224200-114			
	134	A3BD213407	CS14151110450	TC00140230	GRFT224200-134			
	154	A3BD215407	CS14151310500	TC00140250	GRFT224200-154			
	174	A3BD217407	CS14151510550	TC00140250	GRFT224200-174			

Front Assembly Spare Part

Item code	Size 04		Item code	Size 05		Item code	Size 07	
	Nut/Front	Tip		Nut/Front	Tip		Nut/Front	Tip
A3NOS0307061-1	A3OS030706	A3TN0306161-1	A3NOS110101-1	A3OS11010	A3TN109281-1	A3NOS212121-1	A3OS21212	A3TN211351-1
A3NOS0307061-2		A3TN0306161-2	A3NOS110103-1		A3TN109283-1	A3NOS212123-1		A3TN211353-1
A3NOS0307063-1		A3TN0306163-1	A3NOS110104-1		A3TN109284-1	A3NOS212124-1		A3TN211354-1
A3NPS0307061-1	A3PS030706	A3TN0306161-1	A3NOS110101-3	A3PS10810	A3TN109281-3	A3NOS212121-3	A3PS21012	A3TN211351-3
A3NPS0307061-2		A3TN0306161-2	A3NPS108101-1		A3TN109281-1	A3NPS210121-1		A3TN211351-1
A3NPS0307063-1		A3TN0306163-1	A3NPS108103-1		A3TN109283-1	A3NPS210123-1		A3TN211353-1
A3NPX0307061-1	A3PX030706	A3TN0306161-1	A3NPS108104-1	A3PX10810	A3TN109284-1	A3NPS210124-1	A3PX21012	A3TN211354-1
A3NPX0307061-2		A3TN0306161-2	A3NPS108101-3		A3TN109281-3	A3NPS210121-3		A3TN211351-3
A3NPX0307063-1		A3TN0306163-1	A3NPX108101-1		A3TN109281-1	A3NPX210121-1		A3TN211351-1
A3NSX0305071-1	A3SX030507	A3TN0306161-1	A3NPX108103-1	A3PX10810	A3TN109283-1	A3NPX210123-1	A3PX21012	A3TN211353-1
A3NSX0305071-2		A3TN0306161-2	A3NPX108104-1		A3TN109284-1	A3NPX210124-1		A3TN211354-1
A3NSX0305073-1		A3TN0306163-1	A3NPX108101-3		A3TN109281-3	A3NPX210121-3		A3TN211351-3
			A3NSX105101-1		A3TN109281-1	A3NSX207121-1		A3TN211351-1
		A3NSX105103-1	A3NSX105103-1	A3TN109283-1	A3NSX207123-1	A3TN211353-1		
		A3NSX105104-1	A3NSX105104-1	A3TN109284-1	A3NSX207124-1	A3TN211354-1		
		A3NSX105101-3	A3NSX105101-3	A3TN109281-3	A3NSX207121-3	A3TN211351-3		



TN tip spare part list

Size	1 exit			3 exits copper
	copper	HBM-CDC	TZM-SHN	
Size 04	A3TN0306161-1	A3TN0306163-1	*	*
	A3TN0306161-2			
Size 05	A3TN109281-1	A3TN109283-1	A3TN109284-1	A3TN109281-3
Size 07	A3TN211351-1	A3TN211353-1	A3TN211354-1	A3TN211351-3

→ A3 POS+PPS+PPX+PSX Series



POS

- Topless direct gate or on a sprue gate
- Open flow little shear stress
- Fast gate cooling

PPS

- Topless direct gate or on a sprue gate
- Open flow little shear stress
- Exchangeable gate, gate separated from mould plate

PPX

- Direct gate or on a sprue gate small residue on the part
- Open flow little shear stress
- Gating on contour or with a sprue gate
- Exchangeable gate, gate separated from mould plate

PSX

- Perfect hot to cold solution
- Direct gate on the part, reduced stringing
- Exchangeable front, gate separated from mould plate
- Excellent for glass filled resins and high temperature moulding

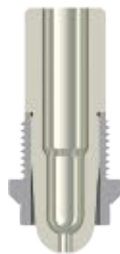

POS

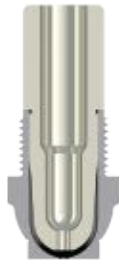

PPS



PPX



PSX
NEW

Size	Size 04	Size 05	Size 07
LA	64~114	64~134	74~174
Feed ϕ	4	5	7
Gate ϕ	0.6~1.5	0.6~2	0.8~3

Shot Weight(g)			
Low	100	300	600
Medium	60	125	310
High	7	25	60

→ A3 POS+PPS+PPX+PSX Guide

Order sample:



A3 - POS - 094 - 05

Nozzle series	Nut/Front type	LA	Feed dia
---------------	----------------	----	----------

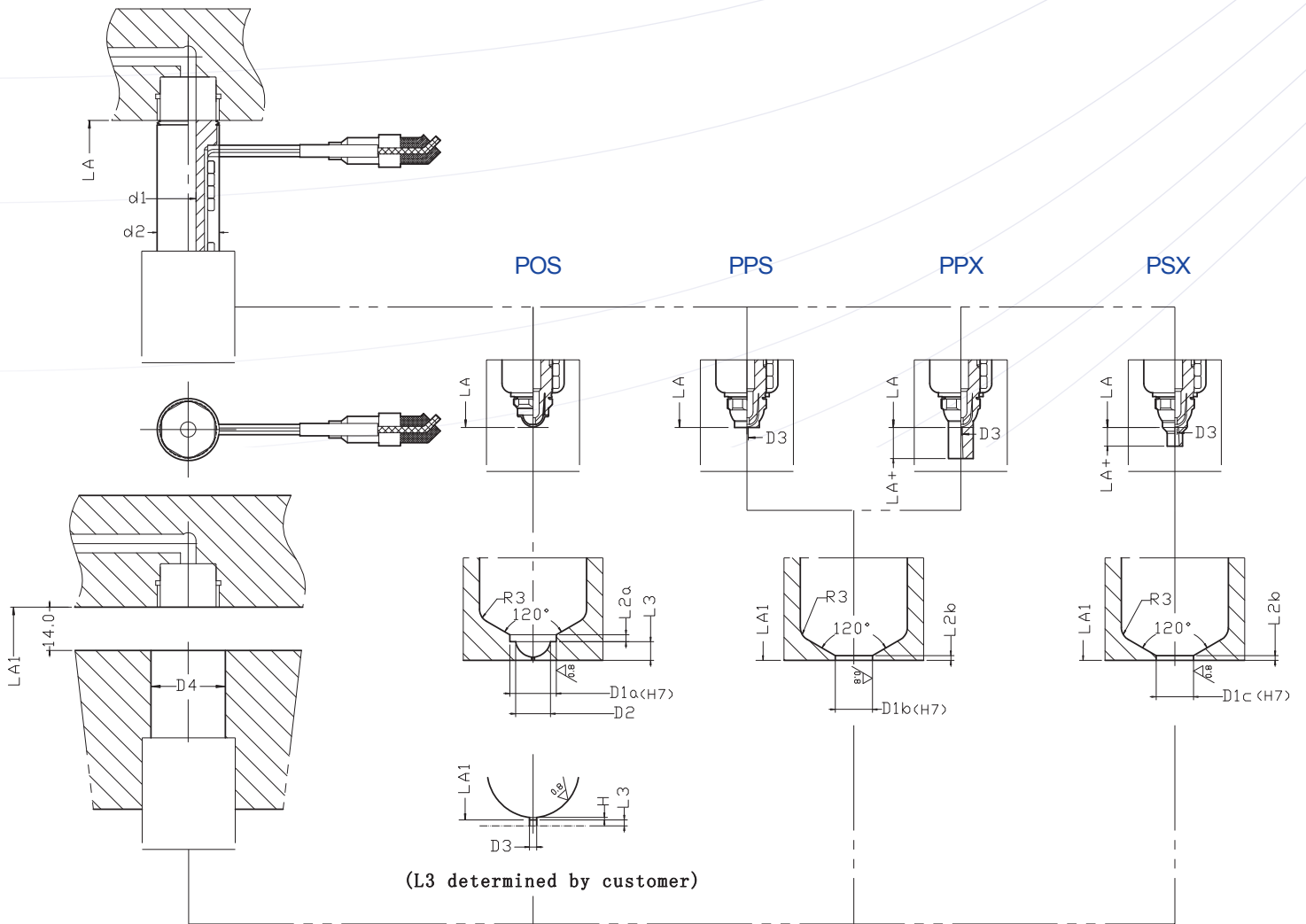

→ A3 POS+PPS+PPX+PSX Dimension

(mm)

A3+POS PPS PPX PSX																	
Nozzle	Size	04					05					07					
	LA	64	74	94	114	134	64	74	94	114	134	74	94	114	134	154	174
	LA+	6					10(PX),6(SX)					15(PX),7(SX)					
	d1	4					5					7					
	d2	13					20					23					
Mould	LA1	64.15	74.17	94.21	114.25	134.29	64.15	74.17	94.21	114.25	134.29	74.17	94.21	114.25	134.29	154.33	174.37
	L2a	1.1					2					2.5					
	L2b	1					2					2					
	L3	1.7					3.5					3.5					
	D1a	6					10					12					
	D1b	6					8					10					
	D1c	5					5					7					
	D2	4.5					7.5					9					
	D3	1.5≥0.6					3≥0.6					4≥0.8					
	D4	15					23					27					
	H	0.2					0.2					0.2					

→ A3 POS+PPS+PPX+PSX Spare Parts

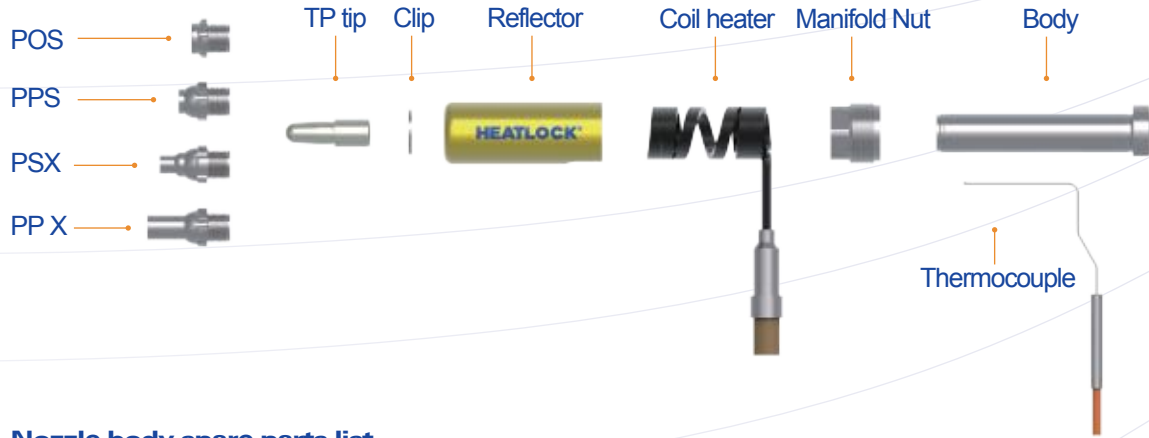

Nozzle body spare parts list

Size	Nozzle LA	Body	Coilheater	Thermocouple	Reflector	Manifold Nut	Spring Clip
04	64	A3BD106404	CS20080500200	TC00140200	GRFT113120-064	A3KG1413	F-S-SPRINGCLIP-8408
	74	A3BD107404	CS20080600250	TC00140210	GRFT113120-074		
	94	A3BD109404	CS20080800300	TC00140220	GRFT113120-094		
	114	A3BD111404	CS20081000350	TC00140220	GRFT113120-114		
05	64	A3BD106405	CS14120430200	TC00140200	GRFT120120-064	A3KG2016	F-S-SPRINGCLIP-1210
	74	A3BD107405	CS14120530225	TC00140210	GRFT120120-074		
	94	A3BD109405	CS14120730250	TC00140220	GRFT120120-094		
	114	A3BD111405	CS14120930350	TC00140220	GRFT120120-114		
	134	A3BD113405	CS14121130350	TC00140250	GRFT120120-134		
07	74	A3BD207407	CS14150510300	TC00140200	GRFT224200-074	A3KG2416	F-S-SPRINGCLIP-1410
	94	A3BD209407	CS14150710350	TC00140210	GRFT224200-094		
	114	A3BD211407	CS14150910450	TC00140220	GRFT224200-114		
	134	A3BD213407	CS14151110450	TC00140230	GRFT224200-134		
	154	A3BD215407	CS14151310500	TC00140250	GRFT224200-154		
	174	A3BD217407	CS14151510550	TC00140250	GRFT224200-174		

Front Assembly Spare Parts

Item code	Size 04		Item code	Size 05		Item code	Size 07	
	Nut/Front	Tip		Nut/Front	Tip		Nut/Front	Tip
A3POS030706	A3OS030706	A3TP030615	A3P0511010	A3OS11010	A3TP109271	A3POS21212	A3OS21212	A3TP211331
A3PPS030706	A3PS030706		A3PPS10810	A3PS10810		A3PPS21012	A3PS21012	
A3PPX030706	A3PX030706		A3PPX10810	A3PX10810		A3PPX21012	A3PX21012	
A3PSX030507	A3SX030507		A3PSX10510	A3SX10510		A3PSX20712	A3SX20712	

→ A3 VOS+VGS+VGX+VSX Series



VOS

- Pneumatic valve gate
- No residue on part
- Fast gate cooling

VGS

- Pneumatic valve gate
- No residue on part
- Exchangeable gate, gate separated from mould plate

VGX

- Pneumatic valve gate
- Direct gate or on a sprue gate small residue on the part
- Gating on contour or with a sprue gate
- Exchangeable gate, gate separated from mould plate

VSX

- Pneumatic valve gate
- Perfect hot to cold solution
- Direct gate on the part, reduced stringing
- Exchangeable front, gate separated from mould plate
- Excellent for glass filled resins and high temperature moulding

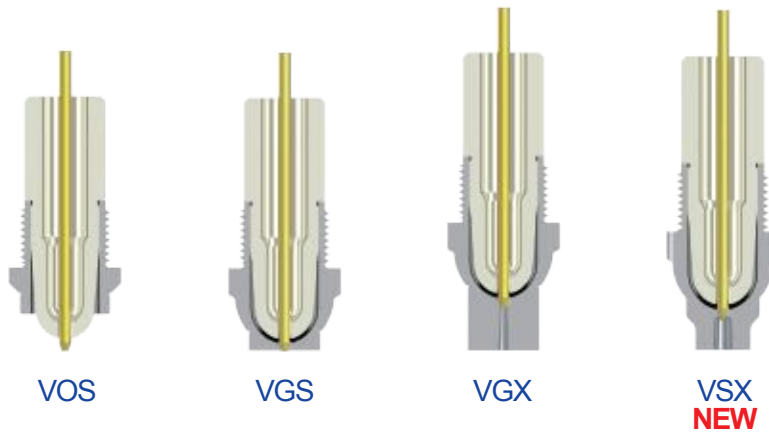

Size	Size 05	Size 07
LA	64~134	74~174
Feed ϕ	5	7
Gate ϕ	≈ 0.8	≈ 1.0

Shot Weight(g)		
Low	200	500
Medium	80	200
High	20	50

→ A3 VOS+VGS+VGX+VSX Guide

Order sample:



A3 - VOS - 094 - 05

Nozzle series Nut/Front type LA Feed dia

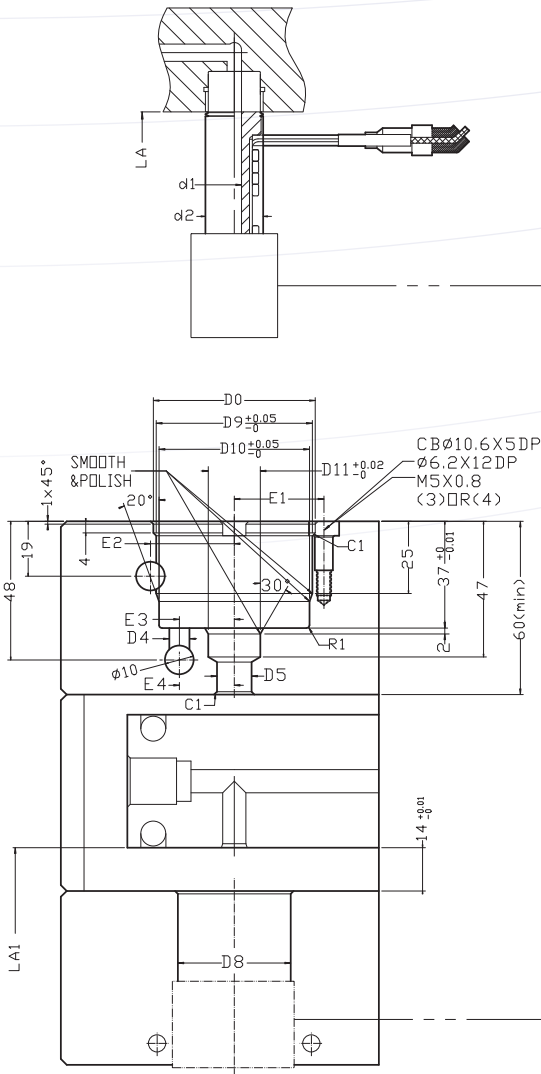

VOS

VGS

VGX

VSX

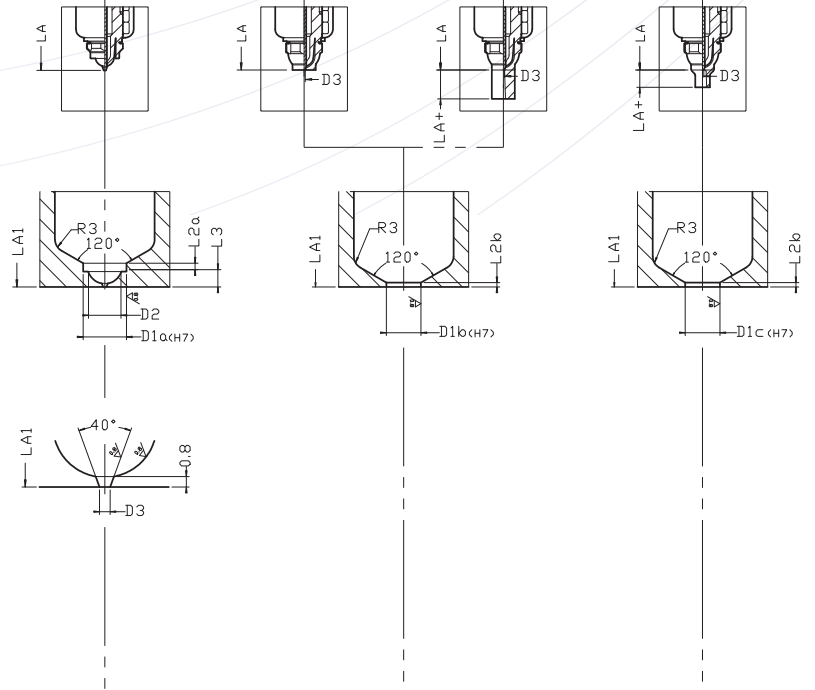

→ A3 VOS+VGS+VGX+VSX Dimension

(mm)

A3+VOS VGS VGX VSX														
Nozzle	Size	05					07							
	LA	64	74	94	114	134	74	94	114	134	154	174		
	LA+	10(PX),6(SX)					15(PX),7(SX)							
	d1	5					7							
	d2	20					23							
	D3	≥0.8					≥1.0							
Mould	LA1	64.15	74.17	94.21	114.25	134.29	74.17	94.21	114.25	134.29	154.33	174.37		
	L2a	2					2.5							
	L2b	1					1.5							
	L3	3.5					3.5							
	D1a	10					12							
	D1b	8					10							
	D1c	5					7							
	D2	7.5					9							
	D8	23					27							
	H	0.8					0.8							

→ A3 VOS+VGS+VGX+VSX Spare Parts

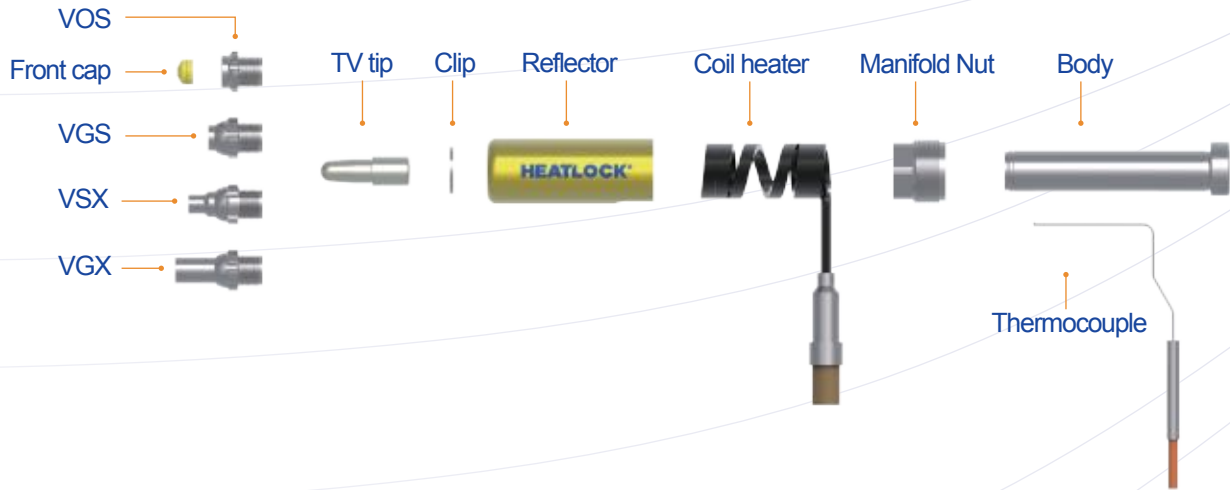

Nozzle body spare parts list

Size	Nozzle LA	Body	Coilheater	Thermocouple	Reflector	Manifold Nut	Spring Clip	Front cap
05	64	A3BD106405	CS14120430200	TC00140200	GRFT120120-064	A3KG2016	F-S-SPRINGCLIP-1210	A3VGFC057939 (optional)
	74	A3BD107405	CS14120530225	TC00140210	GRFT120120-074			
	94	A3BD109405	CS14120730250	TC00140220	GRFT120120-094			
	114	A3BD111405	CS14120930350	TC00140220	GRFT120120-114			
	134	A3BD113405	CS14121130350	TC00140250	GRFT120120-134			
07	74	A3BD207407	CS14150510300	TC00140200	GRFT224200-074	A3KG2416	F-S-SPRINGCLIP-1410	A3VGFC079441 (optional)
	94	A3BD209407	CS14150710350	TC00140210	GRFT224200-094			
	114	A3BD211407	CS14150910450	TC00140220	GRFT224200-114			
	134	A3BD213407	CS14151110450	TC00140230	GRFT224200-134			
	154	A3BD215407	CS14151310500	TC00140250	GRFT224200-154			
	174	A3BD217407	CS14151510550	TC00140250	GRFT224200-174			

Front Assembly Spare Parts

Item code	Size 05		Item code	Size 07	
	Nut/Front	Tip		Nut/Front	Tip
A3VOS110101	A3OS11010	A3TV109261	A3VOS212121	A3OS21212	A3TV211331
A3VGS108101	A3GS10810		A3VGS210121	A3GS21012	
A3VGX108101	A3GX10810		A3VGX210121	A3GX21012	
A3VSX105101	A3VX10510		A3VSX207121	A3VX20712	
A3VOS110103	A3OS11010	A3TV109263	A3VOS212123	A3OS21212	A3TV21133
A3VGS108103	A3GS10810		A3VGS210123	A3GS21012	
A3VGX108103	A3GX10810		A3VGX210123	A3GX21012	
A3VSX105103	A3VX10510		A3VSX207123	A3VX20712	

→ A3 VG Cylinder Spare Parts

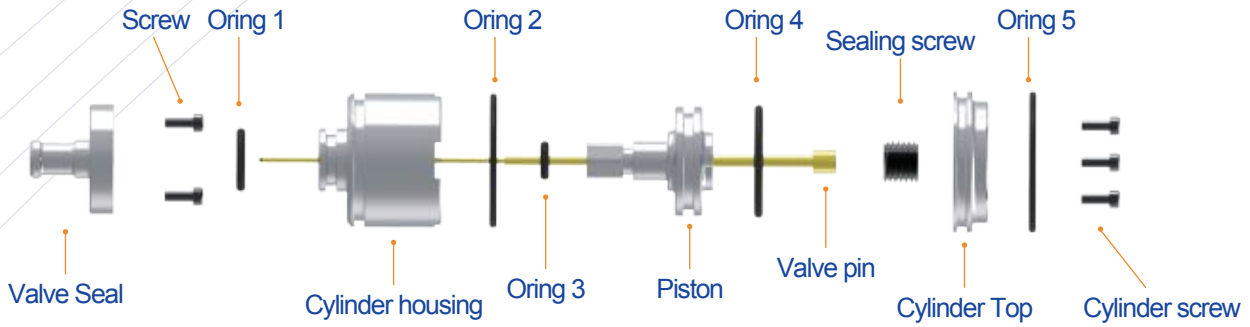

A3 VG Cylinder spare parts

Size	Valve seal	Cylinder housing	Piston	Cylinder top	Valve pins	Screw	Sealing screw	Cylinder screw
A3VG05 A3VG07	CPVS063124	CPCY063835	CPPT063136	CPCT064010	PN0415230 PN0415230-G2 PN0620260 PN0620260-G2 PN0625260 PN0625260-G2 PN0625350 PN0625350-G2	M4X8	GS1215-10	M5X12X10

Size	O-Ring 1	O-Ring 2	O-Ring 3	O-Ring 4	O-Ring 5
A3VG05 A3VG07	ORIN-00228	ORIN-00234	ORIN-00227	ORIN-00233	ORIN-00235

A3VG Cylinder bore dimension

(mm)

Size	D0	D4	D5	D9	D10	D11	E1	E2	E3	E4
ACCP15230 ACCP20260 ACCP25260	42	6	12	40	38	18	24	23	15	18

→ A3 NOX Series

NOX

- Topless direct gate small residue on the part
- One exit options for shear sensitive materials



(mm)

Size	Size 05	Size 07
LA	69~139	79~179
Feed ϕ	5	7
Gate ϕ	0.6~2	0.8~3

Shot Weight(g)		
Low	200	400
Medium	100	260
High	20	50

→ A3 NOX Guide

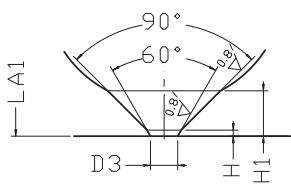
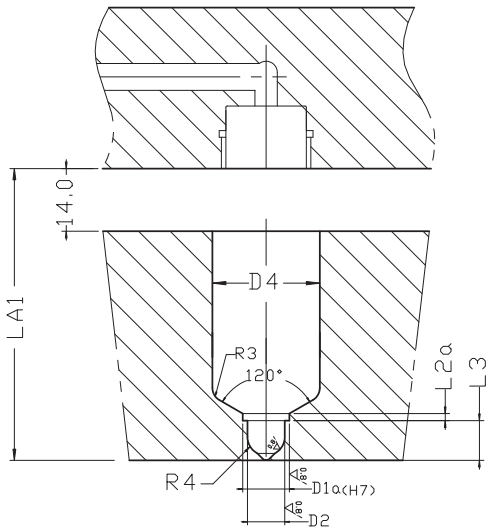
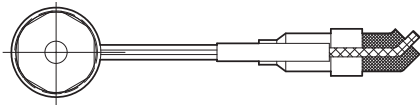
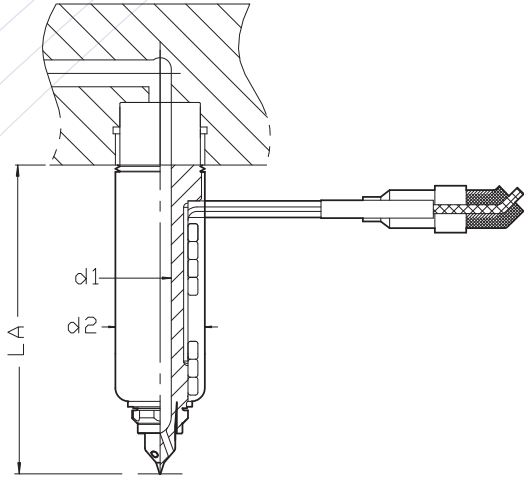

Order example:



A3 - NOX - 095 - 05 - 1 - 3

Nozzle series	Nut type	LA	Feed dia	Tip mat.	Exits in tip

Tip codes:

material: 1=copper alloy,
Exits: 1=one exit,3=three exit

→ A3 NOX Dimension

(mm)

A3 NOX													
Nozzle	Size	05					07						
	LA	69	79	99	119	139	79	99	119	139	159	179	
	d1	5					7						
	d2	20					23						
Mould	LA1	69.15	79.17	99.21	119.25	139.29	79.17	99.21	119.25	139.29	159.33	179.37	
	L2a	2					2.5						
	L3	8.5					8.5						
	D1a	10					12						
	D2	8					9						
	D3	2≥0.6					3≥0.8						
	D4	23					27						
	H	0.2					0.2						

→ A3 NOX Spare Parts

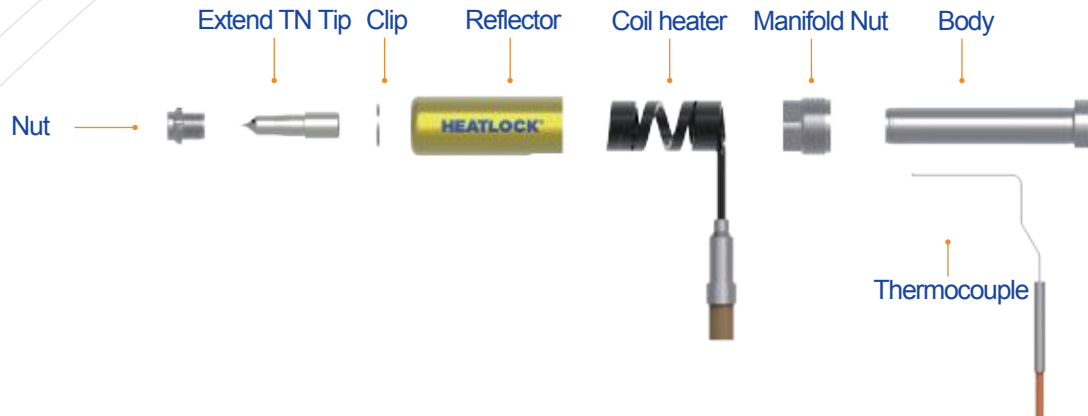

Nozzle body spare parts list

Size	Nozzle LA	Body	Coilheater	Thermocouple	Reflector	Manifold Nut	Spring Clip
05	69	A3BD106405	CS14120430200	TC00140200	GRFT120120-064	A3KG2016	F-S-SPRINGCLIP-1210
	79	A3BD107405	CS14120530225	TC00140210	GRFT120120-074		
	99	A3BD109405	CS14120730250	TC00140220	GRFT120120-094		
	119	A3BD111405	CS14120930350	TC00140220	GRFT120120-114		
	139	A3BD113405	CS14121130350	TC00140250	GRFT120120-134		
07	79	A3BD207407	CS14150510300	TC00140200	GRFT224200-074	A3KG2416	F-S-SPRINGCLIP-1410
	99	A3BD209407	CS14150710350	TC00140210	GRFT224200-094		
	119	A3BD211407	CS14150910450	TC00140220	GRFT224200-114		
	139	A3BD213407	CS14151110450	TC00140230	GRFT224200-134		
	159	A3BD215407	CS14151310500	TC00140250	GRFT224200-154		
	179	A3BD217407	CS14151510550	TC00140250	GRFT224200-174		



Front Assembly Spare Parts

Item code	Size 05		Item code	Size 07	
	Nut	Tip		Nut	Tip
A3NOX110101-1	A3OS11010	A3TN109331-1	A3NOX212121-1	A3OS21212	A3TN211401-1
A3NOX110101-3		A3TN109331-3	A3NOX212121-3		A3TN211401-3

→ A3 Special Hot Runner Solutions

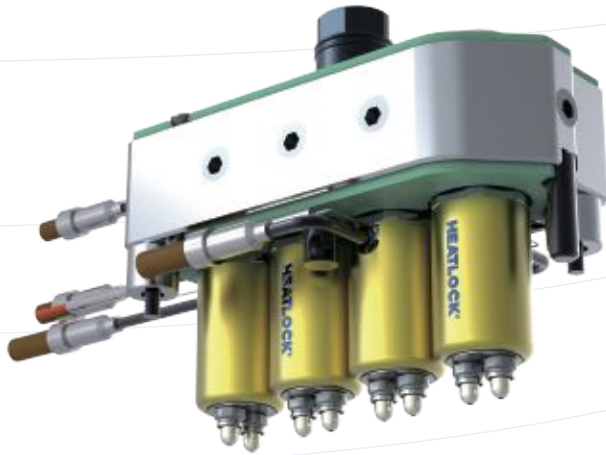

A3 All in one MT (multi tip) nozzles

Small gate pitch, 4 in-line balanced system for vertical injection moulding machines, 2 components moulding. Material TPE white

Pitch between tips: 10mm
Pitch between nozzles: 29mm
Manifold size: 141x61,5x35

A3 All in one TP nozzle compact mini

Compact system 3 in-line balanced system for vertical injection moulding machines, 2 components moulding. Material TPE white

Pitch between nozzles: 40,5mm
Manifold size: 128x46x30

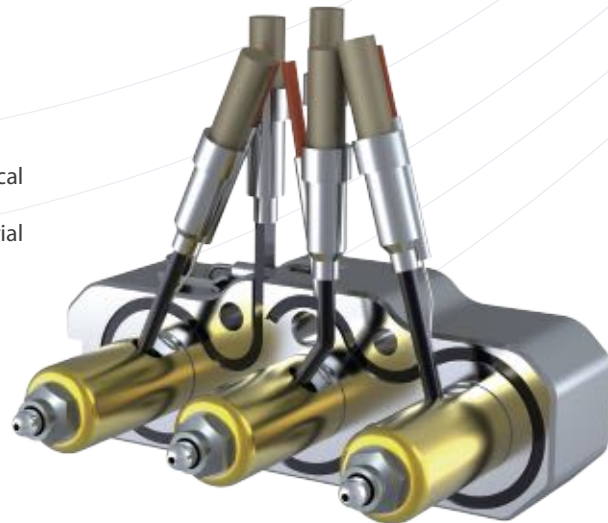

A3 pre-wired system

Plug and play solution ready out of the box just to drop in to your mould.

All wires are bundled in a cable duct fitted with a connector, wired to your specifications

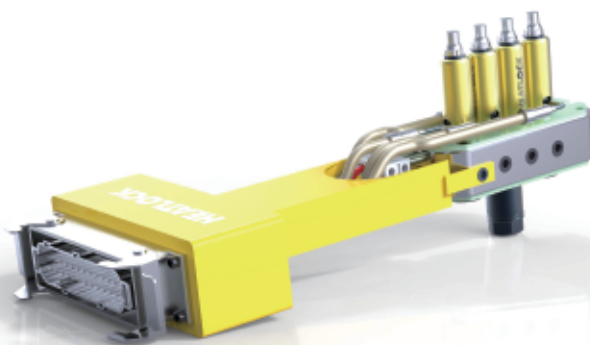

→ A3 Special Hot Runner Solutions

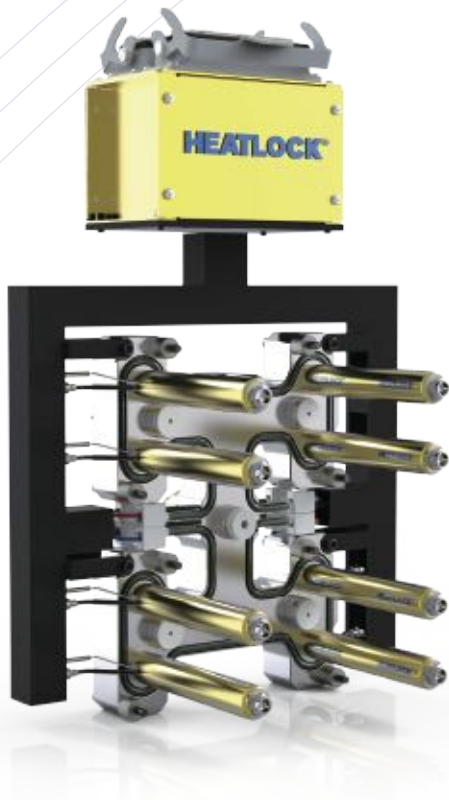

A3 Pre-Wired perfection

Assemble and pre-wired hot runner system with cable duct. Easy to fit to your mould.

A3 Fast Half perfection

Our fast and simple Hot Runner solution, all assemble and pre-wired to the Fast Half plate. Easy to fit to your mould and remove when moulds needs to be serviced.



→ A3 Special Hot Runner Solutions



Hot Half perfection

Fully assembled and test Hot Half designed for longevity. Easy to install and service, for all kind of mould base standards.No compromise design standard.

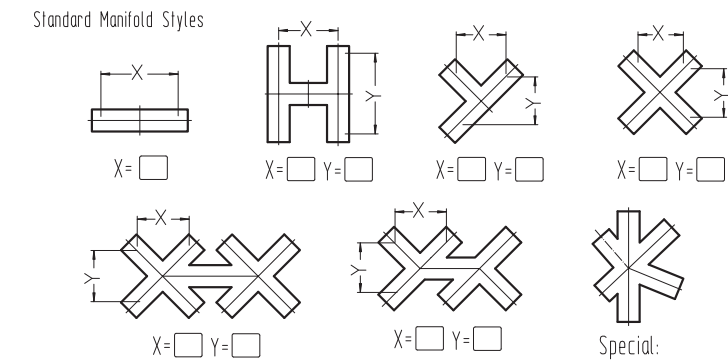
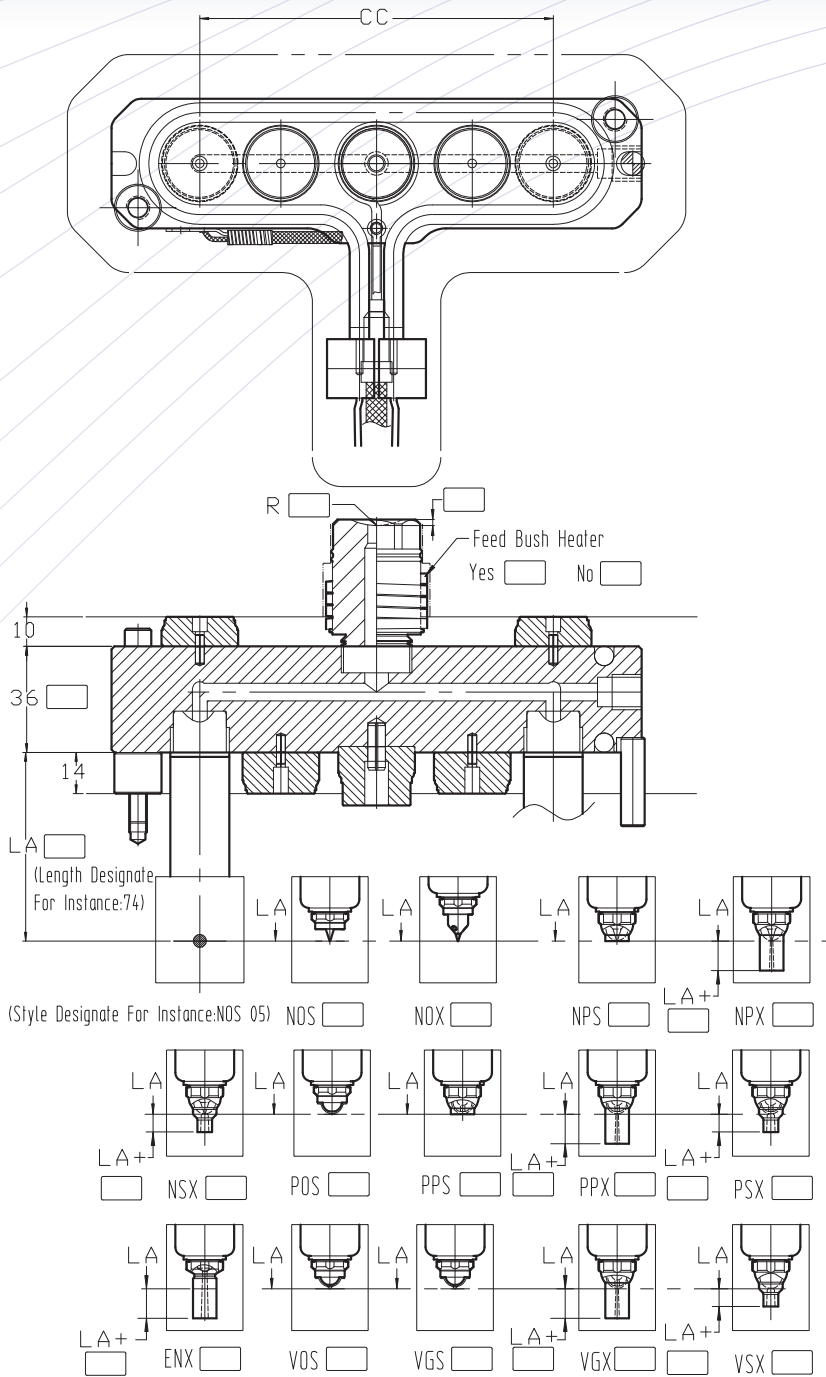

Order example: H6080-94+10NPX1-305-R19D5H

Manifold				Nozzle						Feed bush				
Type	X	Y	—	LA	LA+	Front type	Tip material	Exits in tip	Runner	—	R	D	Heater	
H	60	80	-	94	10	NPX	1	-	3	05	-	R19	D5	H

Please provide the following information:

Customer Quote NO.:	
Company:	
Contact:	Date:
Address:	
Tel:	
Fax:	
E-mail:	
Product Description:	
Material:	Glass Filled: %
	Frame Retardant:
Per Product Weight:	
NO. of Cavities:	
NO. of Gates Per Product:	
Wall Thickness:	
Remarks:	